

1999-11-28

A Gas Analysis Method for Determining the Perchlorate Current Efficiency and Other Applications

Zhigang Shao

Baolian Yi

Recommended Citation

Zhigang Shao, Baolian Yi. A Gas Analysis Method for Determining the Perchlorate Current Efficiency and Other Applications[J]. *Journal of Electrochemistry*, 1999 , 5(4): Article 6.

DOI: 10.61558/2993-074X.2727

Available at: <https://jelectrochem.xmu.edu.cn/journal/vol5/iss4/6>

This Article is brought to you for free and open access by Journal of Electrochemistry. It has been accepted for inclusion in Journal of Electrochemistry by an authorized editor of Journal of Electrochemistry.

A Gas Analysis Method for Determining the Perchlorate Current Efficiency and Other Applications

Shao Zhigang* Yi Baolian

(Dalian Institute of Chemical Physics, Chinese Academy of Science, Dalian 116023)

Abstract A method for determining the current efficiency by means of measuring the flow capacity of the cell gas in a perchlorate cell has been proposed. The perchlorate cell system was equipped with an oxygen cathode or a Na^+ ion exchange membrane. This method is simple and convenient as well as accurate in the evaluation of the perchlorate current efficiency in the perchlorate cell as compared with the traditional methods of analysis. It is useful in the investigation of electrochemical problems with high perchlorate concentration, as well as for the assessment of electrocatalytic performance of anode materials. With an oxygen cathode in place of the mild steel cathode in the perchlorate cell, the cell voltage can be reduced and the energy consumption can be lowerde.

Key words Current efficiency, Gas analysis method, Perchlorate

1 Introduction

The perchlorate salt is mainly used in the preparation of firecrackers, fireworks and rocket fuels. With the development of the space flight technologies, its worldwide production output increases year by year. In a cell unit for perchlorate production, the procedure for the chemical analysis of the perchlorate current efficiency is complicated and time-consuming, making it difficult to supervise the perchlorate production process in the industry. Moreover, it is not convenient to study the perchlorate process in a laboratory.

In this paper, a gas analysis method for determining the perchlorate current efficiency was evaluated. Comparing with the traditional analysis methods, this method is simple and convenient.

2 Gas analysis method

2.1 Oxygen of air used as a depolarizing agent

In an industrial perchlorate cell process, mild steel is often used as the cathode and PbO_2/Ti

Received 11 Jan. 1999, accepted 15 April, 1999

* To whom correspondence should be addressed

or platinum as the anode. The overall chemical reaction in the traditional perchlorate cell process can be written as:



When oxygen or air is used as a depolarizing agent, the evolution of hydrogen at the cathode surface can be suppressed and the main reaction is oxygen reduction. Therefore, the overall chemical reaction can be written as:



By employing an oxygen cathode instead of the steel cathode, the cell voltage may be lowered considerably, rendering a possibility of saving $1.23 \text{ V}^{[1]}$. Such an oxygen cathode approach can also eliminate the risk of explosion.

2.2 Analysis of the loss of perchlorate current efficiency

Since there are some side reactions in the cell process, the current efficiency would suffer some losses. Side reactions at the anode may take place as follows:



The anodic loss of the current efficiency is mainly caused by the water oxidation reaction under a regular condition. When the solution becomes too alkaline, the oxidation of the OH^- ions(4) at the anode surface may increase.

Side reactions at the cathode surface may occur as follows:



As a result, we can draw a conclusion that side reactions evolving oxygen will result in a loss of perchlorate current efficiency if the cathode side reactions are neglected.

An asbestos diaphragm may be used to suppress the cathode side reactions(3 ~ 6) in the perchlorate cell using an oxygen cathode, and the current efficiency loss of the cathode is less than one percent, which is negligible.

2.3 The gas analysis method for determining the perchlorate current efficiency

As it is difficult to determine the concentration of the perchlorate, people usually determine the change of the concentration of the chlorate in the perchlorate process. The chemical efficiency may be formulated as follows:

$$a = \frac{2F(V_0C_0 - V_tC_t)}{It} \quad (7)$$

Where η_a is the overall current efficiency for perchlorate formation, F is the Faraday constant (96485C/mol), I is a constant current, V_0 is the initial volume of electrolyte at room temperature, and V_t is the final volume of electrolyte at room temperature. Here C_0 is the initial concentration of the chlorate, and V_t is the final volume of the chlorate.

A simple way to measure the instantaneous current efficiency is by means of the gas analysis method. Neglecting the current loss of the cathode, the loss of current efficiency is mainly caused by the side reactions evolving oxygen gas. No matter which side reactions take place at constant current, evolution of n moles of oxygen needs $4nF$ coulombs in the time interval dt . If the volumetric flow rate of oxygen is expressed by $V_{O_2}^0$ at the standard state, the loss of coulombs caused by the evolution of oxygen (dQ_{O_2}) may be written as:

$$dQ_{O_2} = \frac{4F V_{O_2}^0 dt}{V_0} \quad (8)$$

Where V_0 is the volume in the standard state.

Gas temperature in the bubble-meter is identical to room temperature when the gas volumetric flow rate is small. Considering the difference in gas volume between room temperature and the standard state, we may write:

$$V_{O_2}^0 = \frac{T_0 V_{O_2}}{T_s} \quad (9)$$

Where T_0 is the temperature at standard state, and T_s is the room temperature.

The overall coulomb consumption dQ may be expressed as:

$$dQ = Idt \quad (10)$$

And the gas current efficiency η_b in the perchlorate cell system can be defined as follows:

$$\eta_b = 1 - \frac{dQ_{O_2}}{dQ} \quad (11)$$

Combining Eqs. (8 ~ 10) with equation (11), the expression for gas current efficiency is:

$$\eta_b = 1 - \frac{4F}{I} \left(\frac{T_0}{T_s} \right) \left(\frac{V_{O_2}}{V_0} \right) \quad (12)$$

Owing to the fact that measurement of the flow capacity of the cell gas can be carried out more directly and accurately, Eq. (12) is easier to be treated than Eq. (7) when the current efficiency has to be determined in the electrolyte system. It has two kinds of ways to measure the flow rate of the oxygen gas:

1) By analyzing the O_2 content of the cell gas with a gas chromatograph, which is commonly used in an industrial perchlorate cell process.

2) By changing the construction of the cell, using an oxygen porous gas-diffusion cathode or a Na^+ ion membrane to separate the cathode and anode.

In this paper, we used the second method to measure the flow rate of the oxygen gas.

3 Experimental

The sketch of the perchlorate cell is shown in Fig. 1. Two different kinds of cells were used in the experiments. Fig. 1a shows that the cell was equipped with a Na^+ ion exchange membrane, a PbO_2/Ti anode and a mild steel cathode, while Fig. 1b shows that the cell was equipped with an oxygen cathode and a platinum anode.

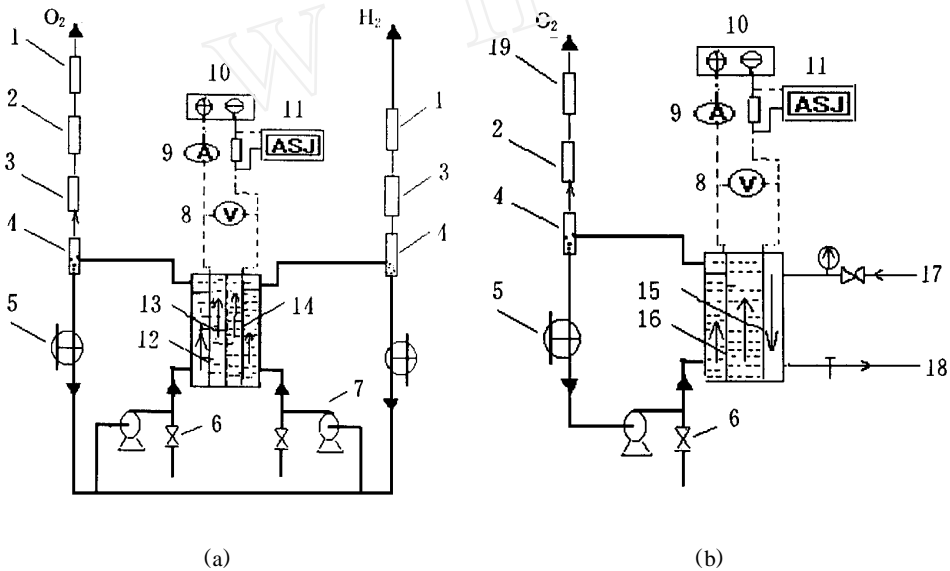

Fig. 1 Apparatus for gas current efficiency determination in a perchlorate cell

- a) The electrolyte cell with an Na^+ ion exchange membrane, a PbO_2/Ti anode and a mild steel cathode
- b) The electrolyte cell with an oxygen cathode and a platinum anode
1. soap bubble-meter
 2. O_3 decomposing catalyst
 3. drying tube
 4. gas and liquid separator
 5. heat exchanger
 6. electrolyte inlet or outlet
 7. magnetic pump
 8. voltmeter
 9. ammeter
 10. DC power
 11. ampere-hour meter
 12. PbO_2/Ti anode
 13. Na^+ ion exchange membrane
 14. mild steel cathode
 15. oxygen gas porous cathode
 16. platinum anode
 17. oxygen gas inlet
 18. oxygen gas outlet
 19. gas collector

The experimental apparatus is shown in Fig. 2.

Fig. 2a shows the laboratory cell which was equipped with a lead dioxide anode, a Nafion 901 Na^+ ion exchange membrane and a mild steel cathode. The electrode area was 10 cm^2 , and the flow rate of the cell oxygen gas was measured by collecting the oxygen gas in a fixed time.

Fig. 2b shows the laboratory cell which was equipped with an oxygen cathode and a platinum anode. The electrolyte was recirculated through the cell with a magnetic pump (CXB-30) whose outlet pressure was about 0.02 MPa . The flow rate of the electrolyte was $6.61 \times 10^{-6}\text{ m}^3\text{ s}^{-1}$. The active area was 140 cm^2 . The oxygen cathode was made according to reference^[2]. At constant cur-

rent; the flow rate of the gas was measured by a soap bubble-meter.

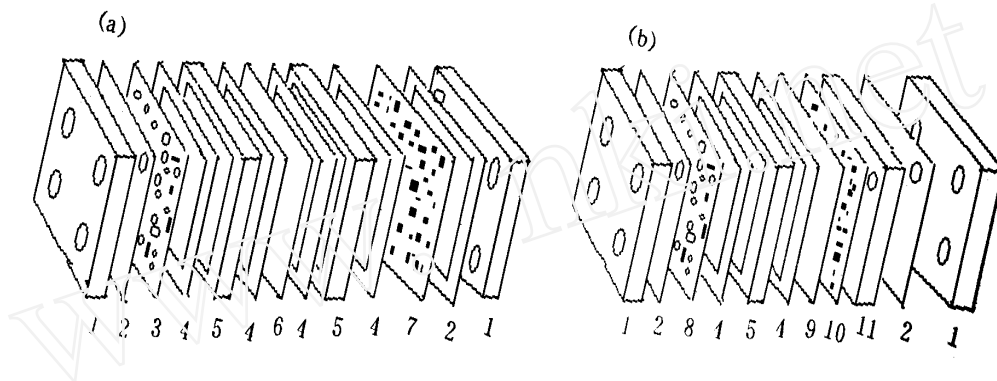

Fig. 2 Schematic construction of the electrolyte cell

- a) The electrolyte cell with an Na^+ ion exchange membrane, a PbO_2/Ti anode and a mild steel cathode
- b) The electrolyte cell with an oxygen cathode and a platinum anode
1. fixed plate 2. rubber plate 3. PbO_2/Ti anode 4. rubber frame 5. organic glass frame
6. Na^+ ion exchange membrane 7. mild steel cathode 8. platinum anode 9. asbestos diaphragm 10. oxygen gas porous cathode 11. stainless steel current collector

The two kinds of cells were generally operated for two to four hours at a temperature of 45 °C until steady-state cell gas was obtained.

The electrolyte was periodically sampled during each experiment. The chloride concentration was determined by titration with an AgNO_3 standard solution and the indicator K_2CrO_4 . The chlorate concentration was determined by auto-oxidation to excessive FeSO_4 , and back titrated with a KMnO_4 solution. Here the FeSO_4 solution was used as a reducing agent. The concentration of perchlorate was determined by measuring the total Cl^- concentration of the mixture and then subtracting the concentrations of NaClO_3 and NaCl as determined above. The total Cl^- concentration was measured as follows: ClO_4^- and ClO_3^- of the solution were reduced by a pulsing NaNO_2 , and then Cl^- was precipitated by the addition of excessive AgNO_3 , and the excessive AgNO_3 was determined by titration with a NH_4CNS solution, using $\text{NH}_4\text{Fe}(\text{SO}_4)_2 \cdot 12\text{H}_2\text{O}$ as the indicator.

4 Results and discussion

4.1 Comparison of current efficiency between the chemical analysis and gas analysis methods

The chemical current efficiency was obtained by Eq. (7) and the gas efficiency by Eq. (12). The experimental data are shown in Table 1. The comparative experiments were operated for different time intervals, chlorate concentrations and current densities to verify the results between the gas and the chemical efficiencies. Table 1 shows the results of the cell with an Na^+ ion exchange

membrane ,in which $[NaClO_3] = 502.9 \text{ g/L}$, $T = 45$,and the average efficiency for perchlorate formation is 82.3 % for the current density of 50 mA/cm^2 ,88.1 % for the current density of 100 mA/cm^2 ,89.3 % for the current density of 150 mA/cm^2 ,and 90.4 % for the current density of 200 mA/cm^2 . Comparing these results with η_b for the same condition ,it can be concluded that both results agree well with each other.

From Table 1 ,we can see that the perchlorate current efficiency increased with increasing $NaClO_3$ concentration. It is possible that the ClO_3^- adsorbed on the electrode surface inhibited oxygen evolution from water discharge ,and this inhibiting effect resulted in the increase of the current efficiency. Table 1 also shows that the perchlorate current efficiency increased with increasing current density. It is probable that the galvanostatic polarization rate of the oxygen evolution and the oxidation rate of chlorate to perchlorate are different^[3]. With the increase of the current density , the increase of the oxidation rate of chlorate to perchlorate was faster than that of the oxygen evolution rate. Moreover ,Table 1 shows that the current density decreased with the increase of the electrolysis time. The reason may be that the concentration of chlorate decreased with the increase of the electrolysis time.

Tab.1 Perchlorate efficiency by the gas analysis and the chemical analysis methods

The cell with a Na^+ membrane	$NaClO_3 = 502.9 \text{ g/L}$				$I = 200 \text{ mA/cm}^2$				$I = 200 \text{ mA/cm}^2$				$I = 200 \text{ mA/cm}^2$			
									$NaClO_3 = 502.9 \text{ g/L}$				$NaClO_3 = 500 \text{ g/L}$			
	$I/\text{mA cm}^{-2}$				$[NaClO_3]/\text{g L}^{-1}$				Time/h				*electricity/Ah			
	50	100	150	200	200	400	500	743	2	6	8	10.8	30	90	120	210
$V_{O_2}/\text{mL/min}$	5.13	6.97	8.28	9.91	27.1	14.8	9.3	3.1	3.1	3.3	4.2	17.6	9.5	7.4	8.8	30.8
$\eta/\%$	80.1	86.5	87.5	89.0	73.7	85.7	91.0	97.0	97.0	96.8	95.9	82.9	90.8	92.8	91.3	70.2
$\alpha/\%$	82.3	88.1	89.3	90.4	74.7	86.9	92.1	99.2	99.2	98.2	97.4	86.2	92.6	94.7	93.1	71.6
	1.027	1.018	1.021	1.016	1.014	1.014	1.021	1.023	1.023	1.014	1.016	1.040				
The cell with an oxygen cathode	$NaClO_3 = 643.4 \text{ g/L}$				$I = 400 \text{ mA/cm}^2$				$I = 400 \text{ mA/cm}^2$				$I = 400 \text{ mA/cm}^2$			
									$NaClO_3 = 710 \text{ g/L}$				$NaClO_3 = 710 \text{ g/L}$			
	$I/\text{mA cm}^{-2}$				$[NaClO_3]/\text{g L}^{-1}$				Time/h				*electricity/Ah			
	1.0	2.0	3.0	4.0	50	200	400	710	4	6	10	15.8	22.2	39.6	63.6	85
$V_{O_2}/\text{mL/min}$	0.43	0.45	0.52	0.55	8.50	3.15	1.11	0.36	0.70	0.63	1.05	1.61	0.40	0.94	2.41	3.36
$\eta/\%$	88.6	94.0	95.4	96.3	35.1	75.9	92.6	97.6	95.3	95.8	93.8	89.2	97.3	93.6	83.7	77.0
$\alpha/\%$	86.7	92.8	93.8	95.7	33.5	74.2	91.5	96.8	93.6	94.3	91.7	87.1	95.4	91.9	82.2	75.6
	0.978	0.987	0.983	0.994	0.954	0.978	0.988	0.992	0.982	0.984	0.986	0.976				

* The chemical efficiency α_a in the varied electricity is calculated by equation 14 , $T = 318 \text{ K}$, $pH = 6 \sim 9$

4.2 Error analysis for the two kinds of current efficiencies

The amount of water vapor in the cell gas was small because experimental temperature was

318 K and the flow rate of the cell gas was low, so that it could be neglected. The ratio of the chemical efficiency to the gas current efficiency η_1 may be defined as follows:

$$\eta_i = \frac{a}{b} \quad (i = 1, 2) \quad (13)$$

Then η_j can be obtained from the following equation:

$$\eta_1 = \frac{1}{n} \sum (\eta_1)_j = 1.020$$

$$\eta_2 = \frac{1}{n} \sum (\eta_2)_j = 0.982$$

Where η_1 is the ratio of the chemical efficiency to the gas current efficiency in the electrolyte cell with a Na^+ ion exchange membrane, a PbO_2/Ti anode and a mild steel cathode. Similarly, η_2 is defined as the ratio of the chemical efficiency to the gas current efficiency in the electrolyte cell with an oxygen cathode and a platinum anode.

From Table 1, there is clearly a difference between the gas current efficiency η_b and the chemical efficiency η_a . When using the Na^+ ion exchange membrane in the perchlorate cell, $\eta_1 = 1.020$. The cause of error might be: 1) The anode and the cathode was separated by the Na^+ ion exchange membrane, but the electrolyte was a unified one, and the hydrogen gas has some solubility in water. The dissolved hydrogen in the solution evolved in the anode chamber, so the flow rate of the oxygen gas was increased. 2) The hydrogen gas was brought by the flow of the electrolyte from the cathode chamber to the anode chamber. Therefore, the chemical efficiency (η_a) was always higher than the gas current efficiency (η_b).

By employing an oxygen cathode in the perchlorate cell, $\eta_2 = 0.982$. The existing of the error might due to: 1) The organic substances in the system might be oxidized; 2) The efficiency loss of the cathode was neglected. Therefore, the chemical efficiency η_a was an average efficiency over a period of time, and was lower than the steady-state gas current efficiency η_b .

Since the value η_j which varies from 0.987 to 1.020, is approximately 1.0, then the gas efficiency may be considered to be identical with the chemical efficiency when it is desired to determine the current efficiency for perchlorate formation.

4.3 Current efficiency in concentrated perchlorate

When the perchlorate cell system is operated for a short time or over several hours, the error of the chemical analysis was larger and the current efficiency might be distorted in concentrated perchlorate, because the formation of perchlorate was too small to compare with the perchlorate in dilute solutions. These results suggest that the chemical efficiency may be evaluated by the gas analysis method. In Eq. (13) we can substitute η_j for η_j and obtain:

$$\eta_a = \eta_j \eta_b \quad (j = 1, 2) \quad (14)$$

Where $\eta_1 = 1.020$, $\eta_2 = 0.982$, and η_b can be determined by Eq. (12). Hence the chemical efficiency in concentrated perchlorate can be determined by the gas analysis method.

4.4 Application of gas analysis method

In the perchlorate cell equipped with a Na^+ ion exchange membrane, an oxygen cathode and a PbO_2/Ti anode, we can get the changes of the gas current efficiency and the chlorate concentration from the electricity (Fig. 3). The initial concentration of the chlorate in the cell was 743.9 g/L , and the final concentration of the chlorate was 3.98 g/L , the overall mean gas current efficiency was 84.7% . When the electricity was 226 Ah , the concentration of the chlorate in the cell was 107 g/L , and the instantaneous gas current efficiency started to decrease. Thus, by means of the gas current efficiency method, we can observe in detail the change of the gas current efficiency with the concentration of the chlorate in the cell.

Typical current density is 250 mA/cm^2 . However, if the stainless cathode is replaced by an oxygen cathode, the cell voltage will be reduced by 0.7 V (Fig. 4). Furthermore, by using the oxygen cathode the possibility of explosion can be eliminated^[4].

5 Conclusions

The current efficiency in a perchlorate cell with a Na^+ exchange membrane or with an oxygen cathode can be determined by measuring the cell gas in the recycling electrolyte. The result of the gas method is consistent with those of the chemical analysis method. It constitutes a simple and convenient method to examine the perchlorate current efficiency. This method is useful for the assessment of electrocatalytic performance of anode materials. When an oxygen cathode is used instead of the steel cathode, the perchlorate cell voltage can be reduced and energy saved.

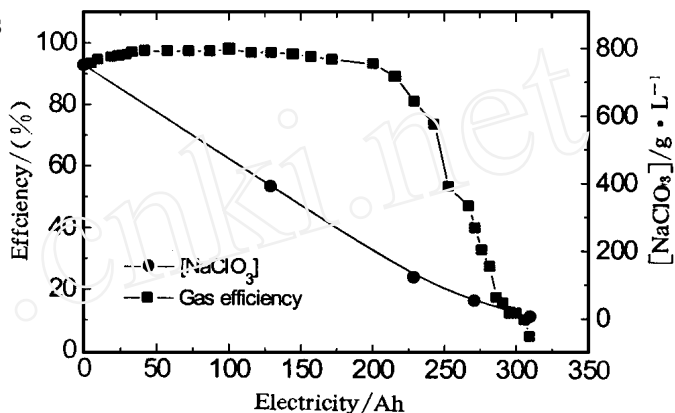

Fig. 3 The changes of the instantaneous gas efficiency and the concentration of chlorate in the perchlorate cell with the electricity

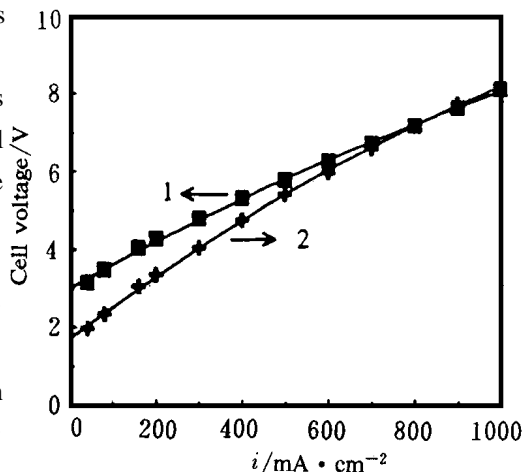

Fig. 4 The change of cell voltage using the oxygen cathode instead of the steel cathode.

(Distance between the anode and the cathode = 11 mm , $\text{NaClO}_3 = 576 \text{ g/L}$)

1. steel cathode 2. oxygen cathode

References

- 1 Bao lian Y J Chem. Ind. & Eng (Eng.) 2 1987 ,227.
- 2 中国科学院技术情报研究所. 科学技术成果报告(航天氢氧燃料电池系统). 北京科学技术文献出版社, 1980:3
- 3 Janssen L J J ,Vander Heyden P D L. Mechanism of anodic oxidation of chlorate to perchlorate on platinum electrodes. J. Appl. Electrochem. ,1995 ,25 :126 ~ 135
- 4 邵志刚,衣宝廉等. 氧阴极用于高氯酸盐电报生产的研究. 电化学 ,1997 ,3(4) :413 ~ 419

一种用于测定高氯酸盐电流效率的气体分析方法及其应用

邵志刚* 衣宝廉

(中国科学院大连化学物理研究所 大连 116023)

摘要 高氯酸盐电解电流效率的化学分析过程复杂、费时. 本文通过改变电解槽结构, 提出一种气体分析方法, 即采用氧阴极或使用一张钠离子交换膜改变电解槽结构, 通过测定电解槽产气量, 得到电解电流效率. 与传统分析方法相比, 气体分析方法既简单又方便. 这种方法特别适用于实验室研究使用和评价阳极材料的电化学性能. 此外, 使用氧阴极代替铁阴极, 可以降低电解电压和节约电能.

关键词 电流效率, 气体分析方法, 高氯酸盐